

Light and Color

D.A. Forsyth

Key issues

- Physical
 - what makes a pixel take its brightness values?
- Inference
 - what can we recover from the world using those brightness values?
- Human
 - What can people do?
 - which suggests problems we might be able to solve



By nickwheeleroz, on Flickr



By nickwheeleroz, on Flickr

Processes

- Cameras
 - film: non-linear
 - CCD: linear, with non-linearities made by electronics
- Light
 - is reflected from a surface
 - got there from a source
- Many effects when light strikes a surface -- could be:
 - absorbed; transmitted; reflected; scattered
 - Simplify
 - Assume that
 - surfaces don't fluoresce
 - surfaces don't emit light (i.e. are cool)
 - all the light leaving a point is due to that arriving at that point

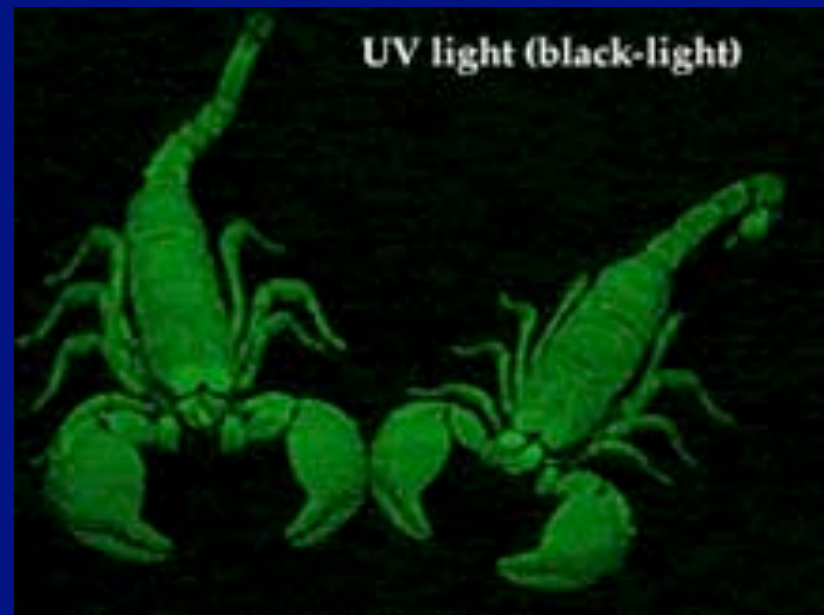

Specularities

- For some surfaces, reflection depends strongly on angle
 - mirrors (special case)
 - incoming direction, normal and outgoing direction are coplanar
 - angle d_{in} , normal and angle d_{out} , normal are the same
 - specular surfaces
 - light reflected in a “lobe” of directions
 - eg slightly battered metal surface
 - can see light sources specularly reflected
 - specularities

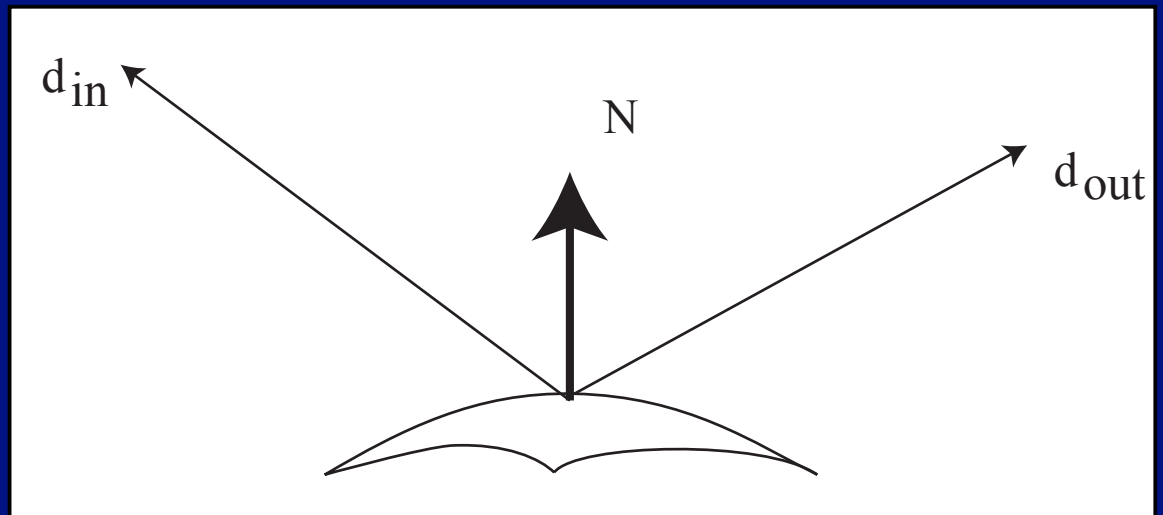



Flickr, by suzysputnik



Flickr, by piratejohnny

- Specularities are relatively easy to detect
 - small and bright (usually)

Diffuse reflection

- Light leaves the surface evenly in all directions
 - cotton cloth, carpets, matte paper, matte paints, etc.
 - most “rough” surfaces
 - Parameter: Albedo
 - percentage of light arriving that leaves
 - range 0-1
 - practical range is smaller

Point source at infinity

- E.g. the sun
 - energy travels in parallel rays
 - energy density received is proportional to $\cos \theta$
- Write:
 - p for albedo
 - S for source vector
 - N for normal
 - I for image intensity

$$I(\mathbf{x}) = \rho(\mathbf{x})\mathbf{S} \cdot \mathbf{N}(\mathbf{x})$$

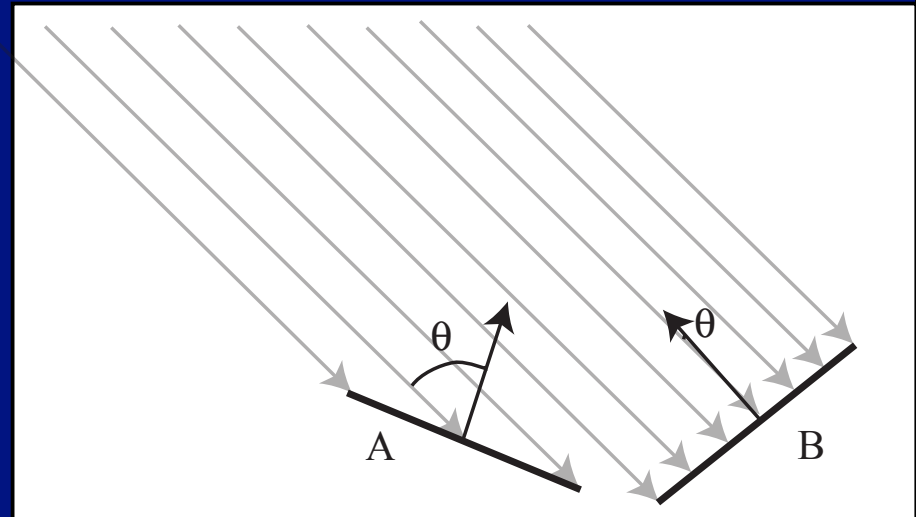

Shadows cast by a point source

- A point that can't see the source is in shadow
- For point sources, the geometry is simple

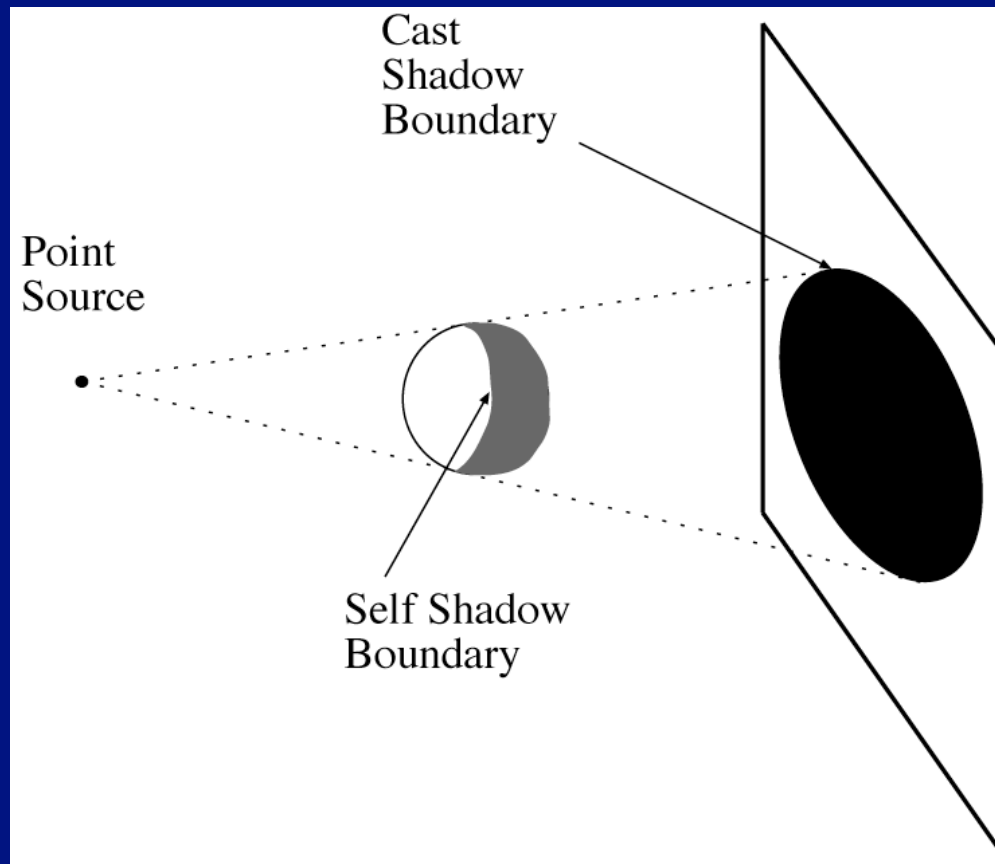

Cues to shape - shadows

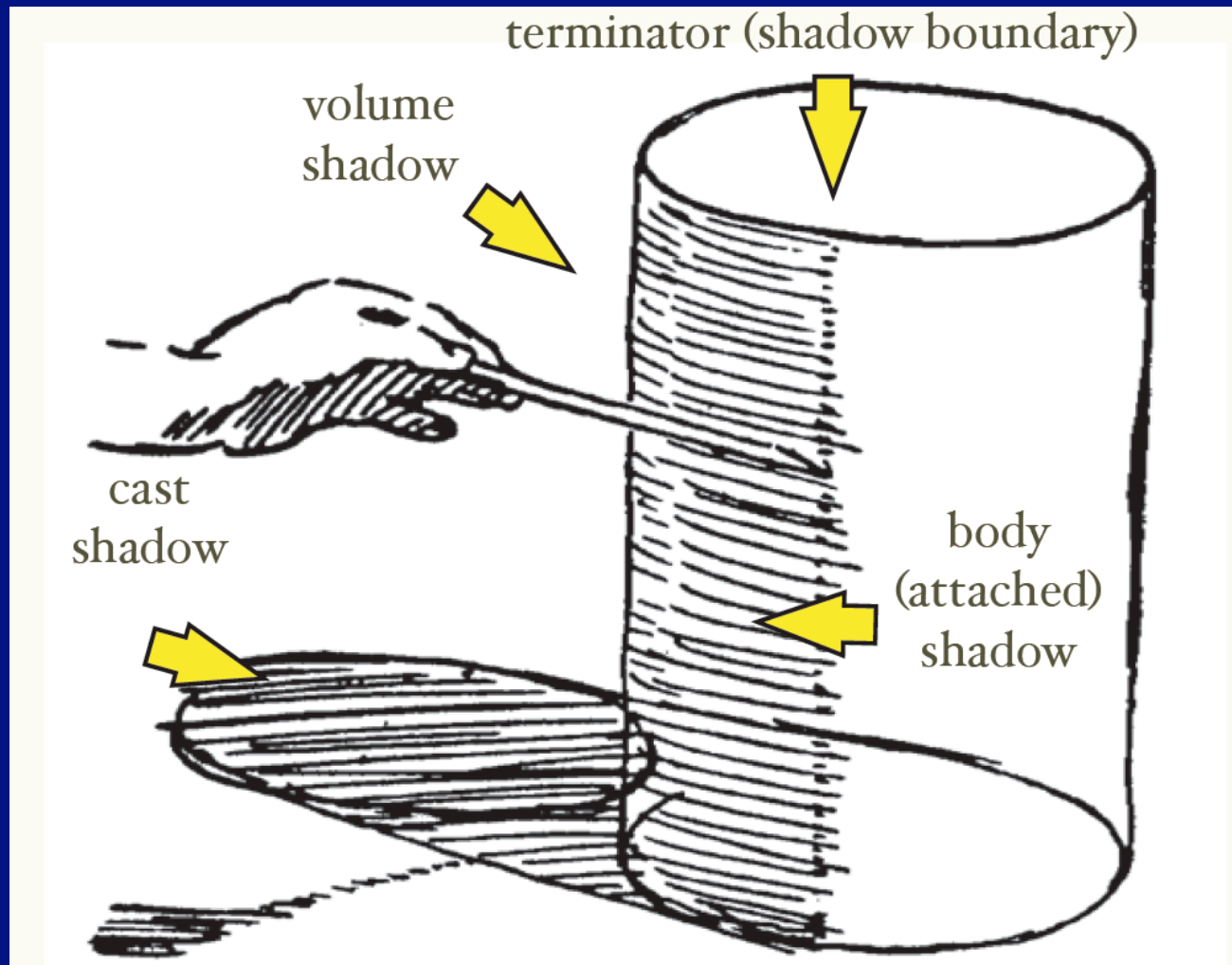

From Koenderink slides on image texture and the flow of light

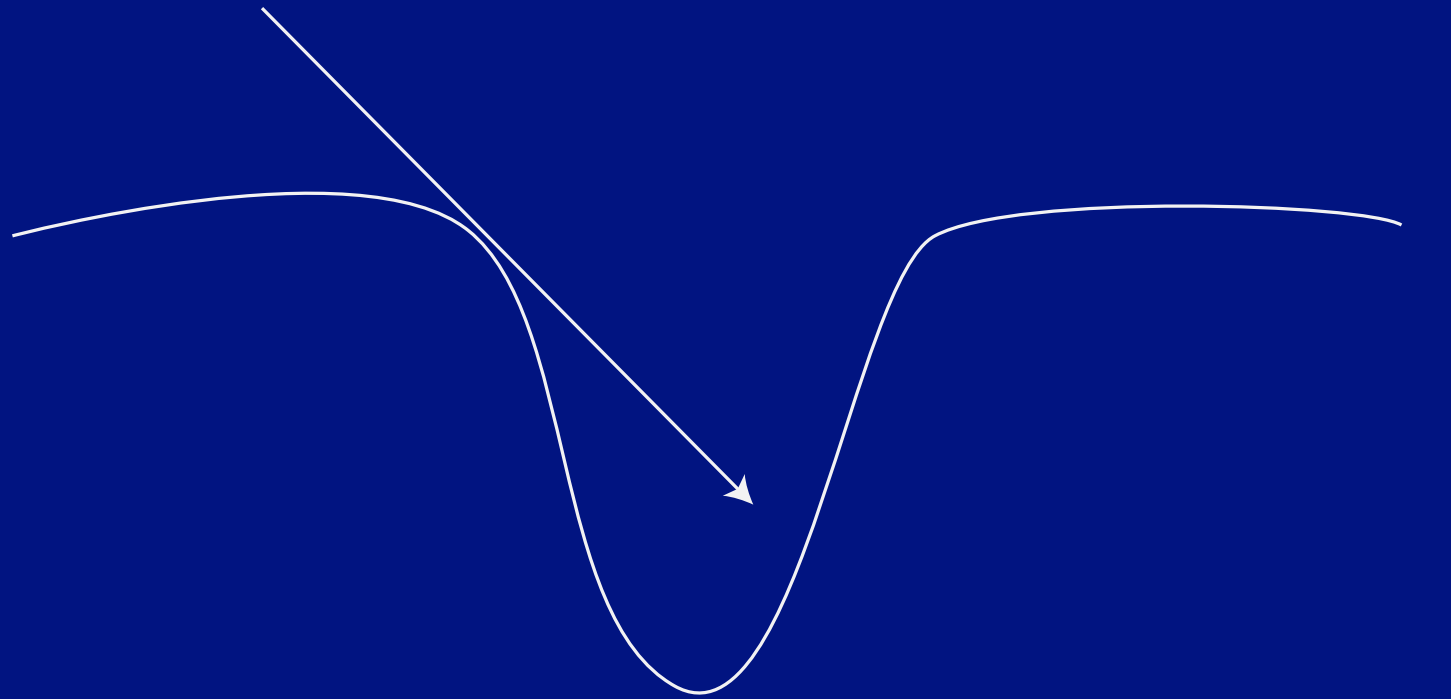

Shadow

Bright



From Koenderink slides on image texture and the flow of light



From Koenderink slides on image texture and the flow of light

Shadow geometry can be very nasty

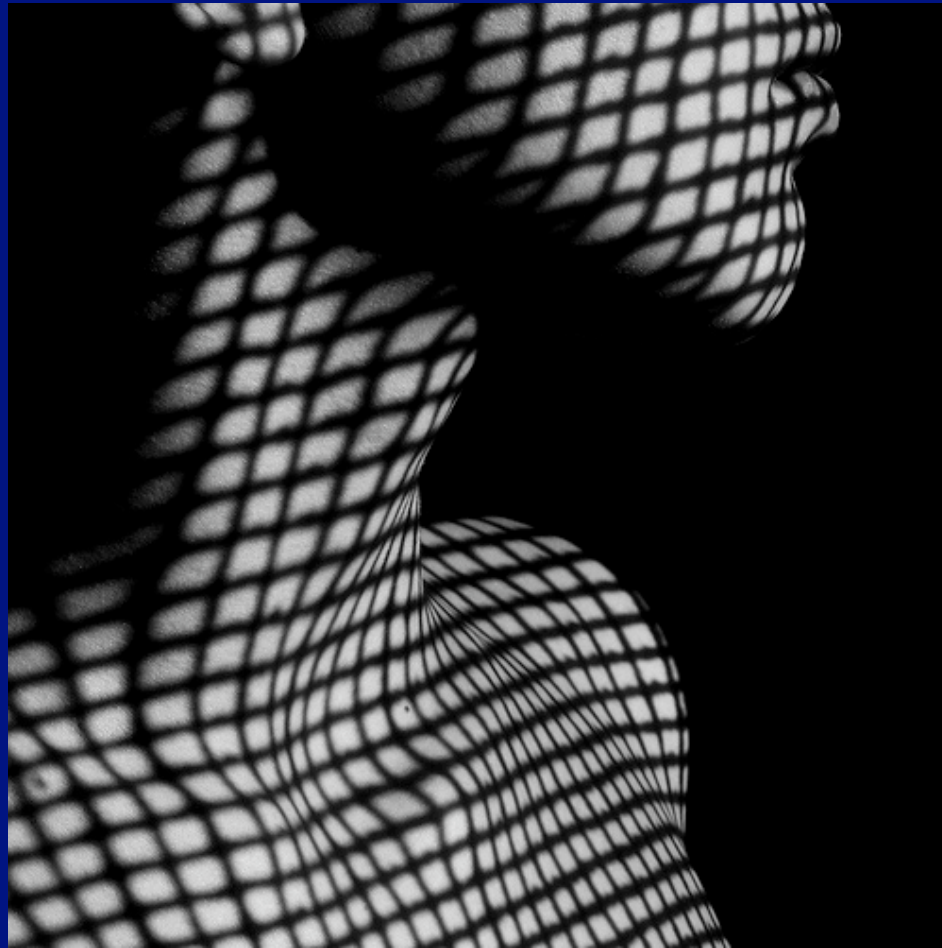

From Hel Des, on Flickr

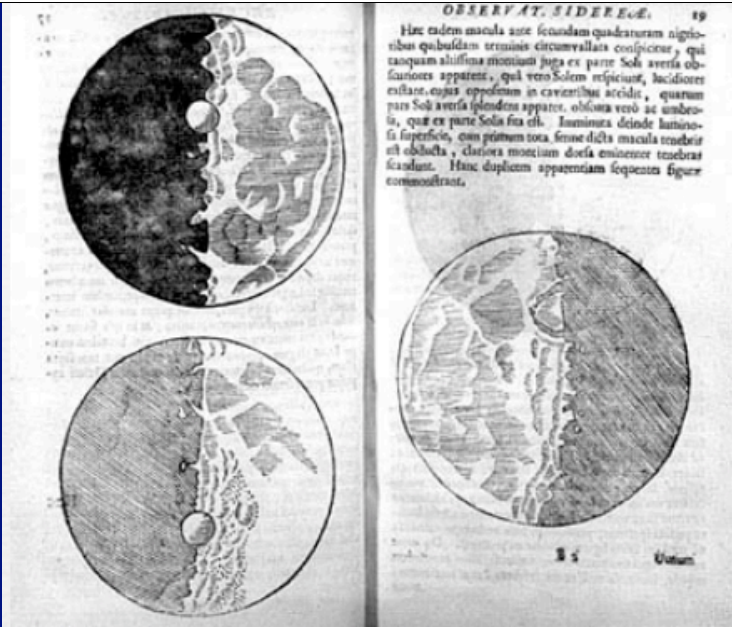

From Koenderink slides on image texture and the flow of light

Photometric stereo

- Assume:
 - a set of point sources that are infinitely distant
 - a set of pictures of an object, obtained in exactly the same camera/object configuration but using different sources
 - A Lambertian object (or the specular component has been identified and removed)

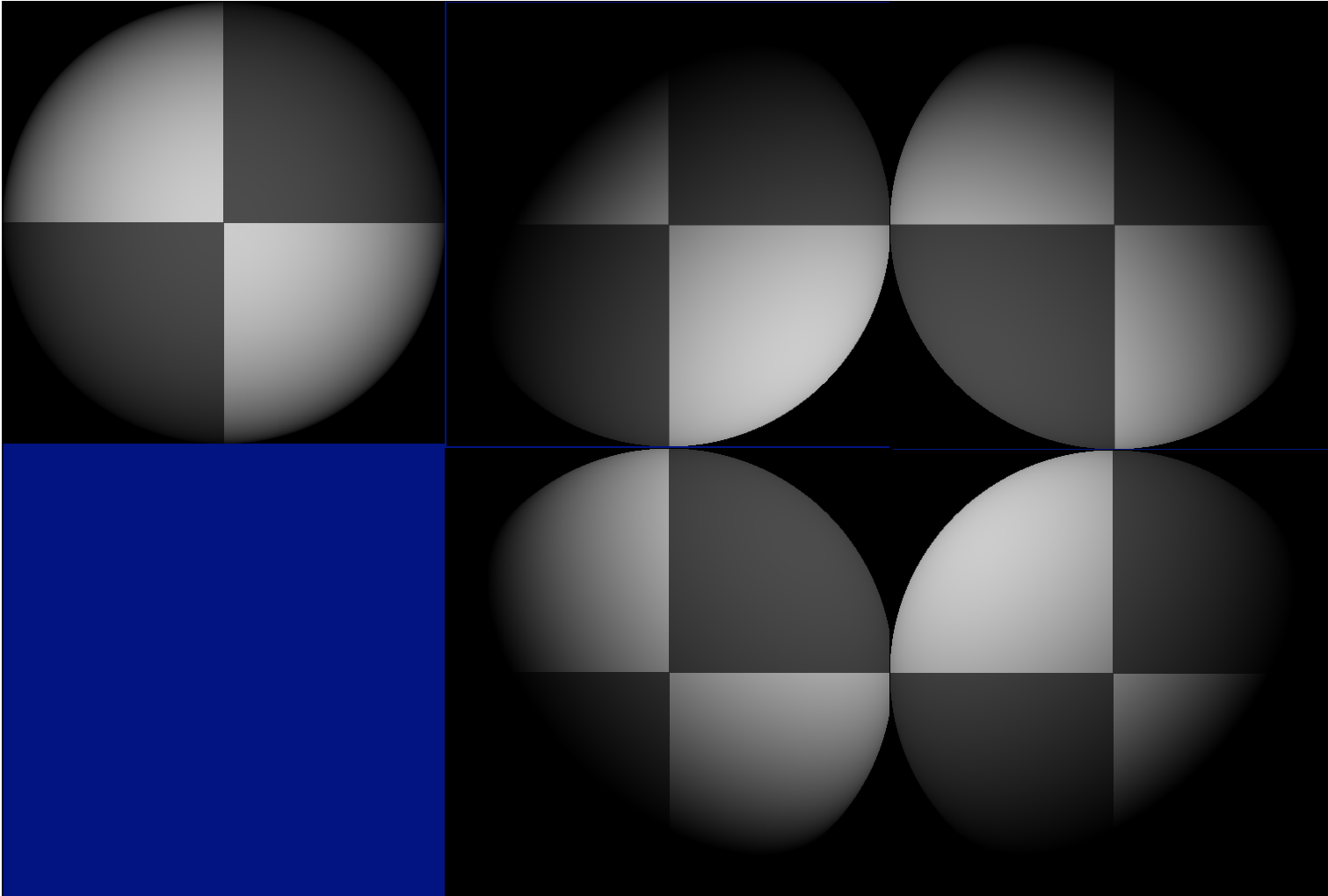

Each image is: $I_i(\mathbf{x}) = \mathbf{S}_i \cdot (\rho(\mathbf{x})\mathbf{N}(\mathbf{x}))$

So if we have enough images with known sources, we can solve for

$$\mathbf{B}(\mathbf{x}) = (\rho(\mathbf{x})\mathbf{N}(\mathbf{x}))$$

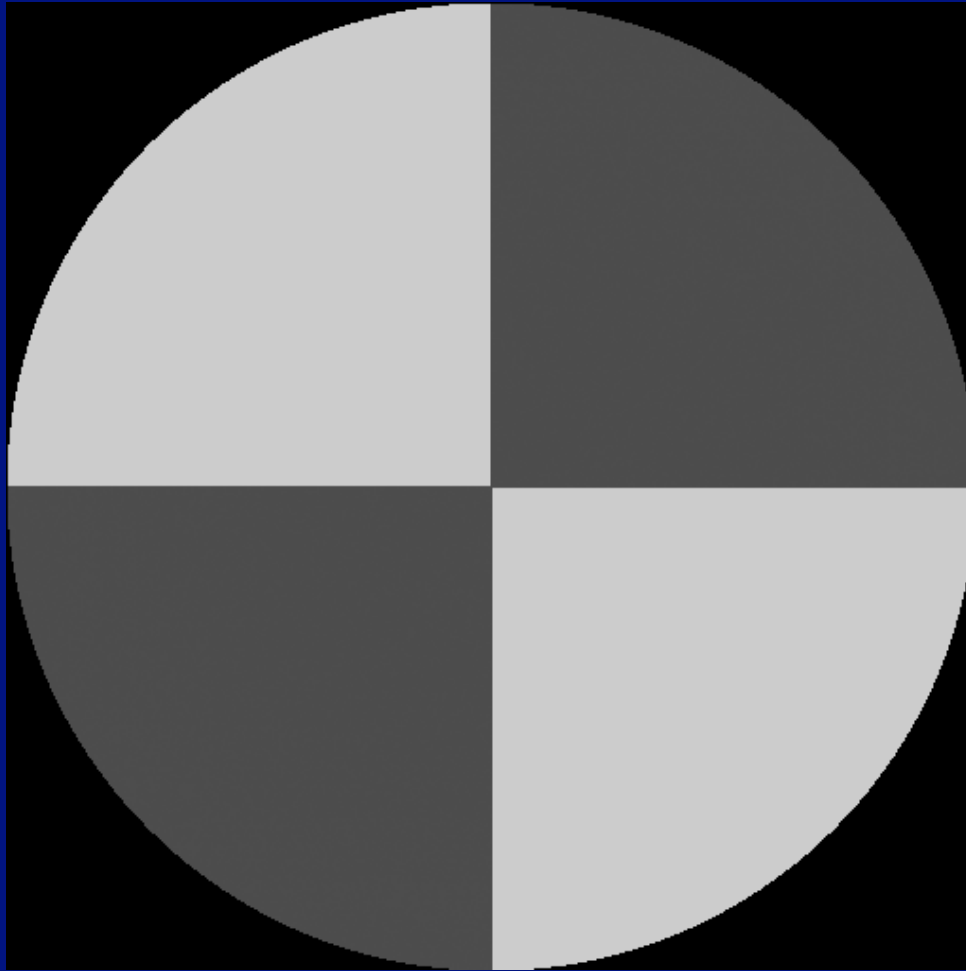

$$\mathbf{B}(\mathbf{x}) = (\rho(\mathbf{x})\mathbf{N}(\mathbf{x}))$$

And the albedo (shown here) is given by:

$$\sqrt{\mathbf{B}(\mathbf{x}) \cdot \mathbf{B}(\mathbf{x})}$$

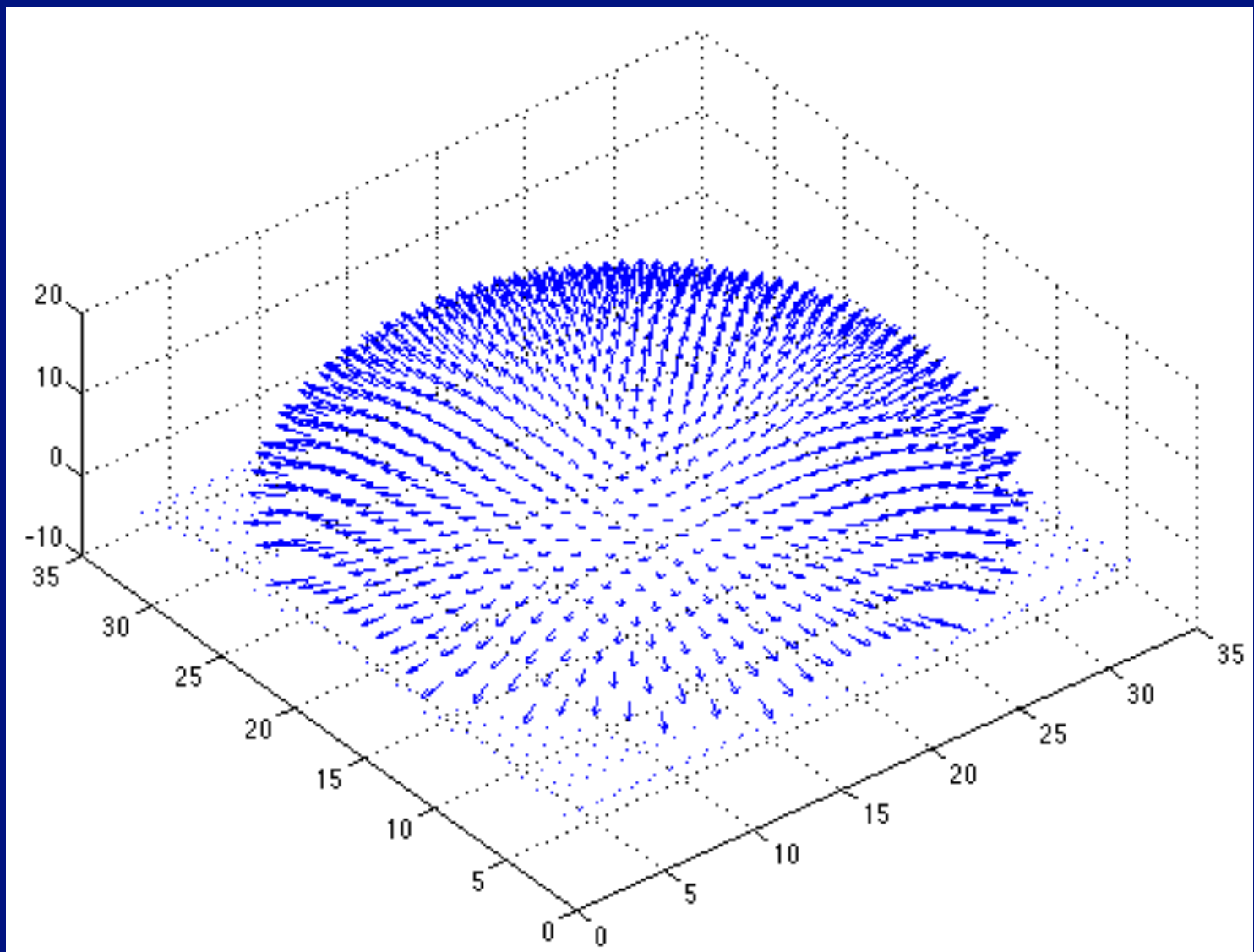

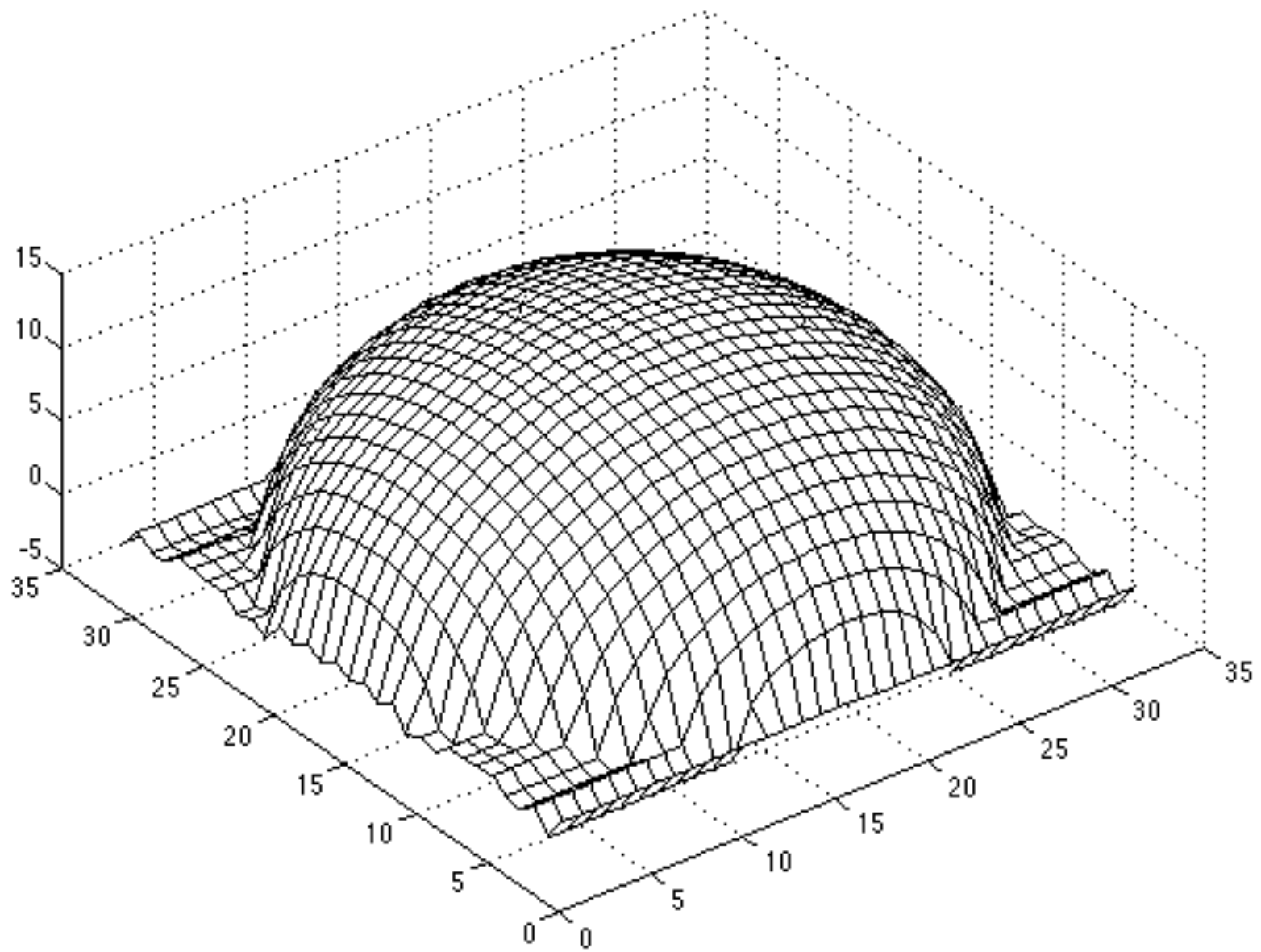

Curious Experimental Fact

- Prepare two rooms, one with white walls and white objects, one with black walls and black objects
- Illuminate the black room with bright light, the white room with dim light
- People can tell which is which (due to Gilchrist)

- Why? (a local shading model predicts they can't).

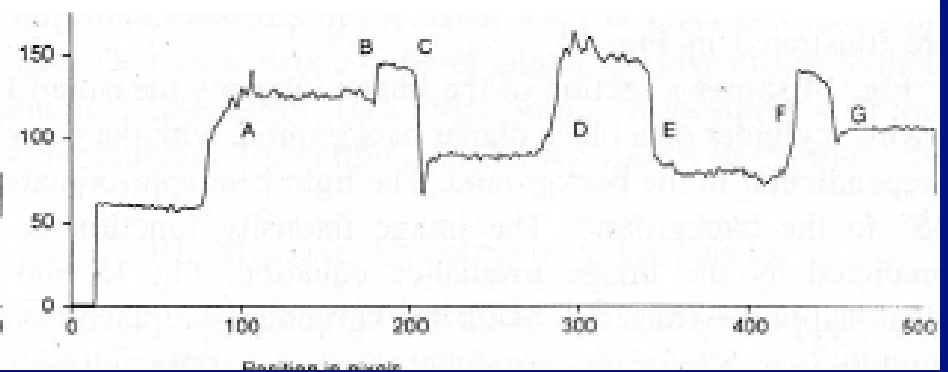
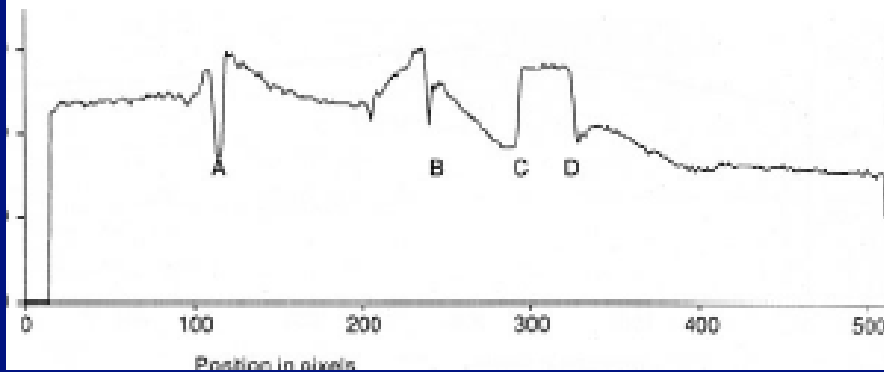
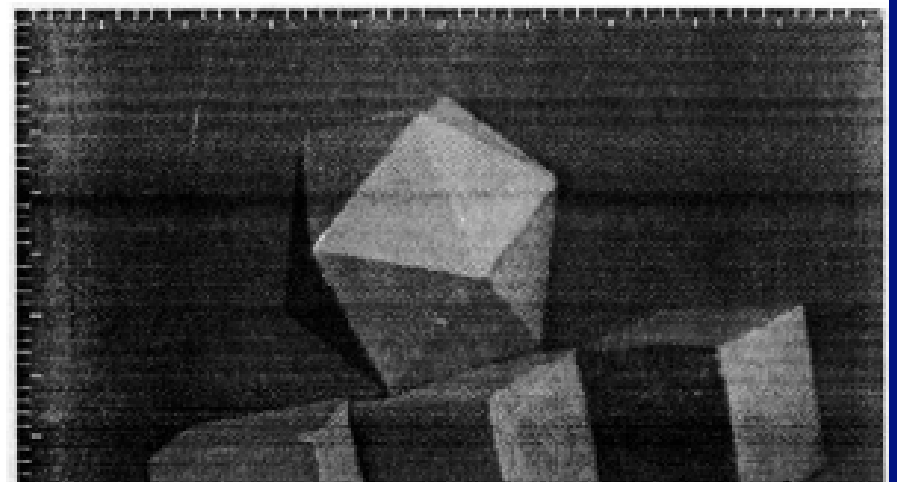
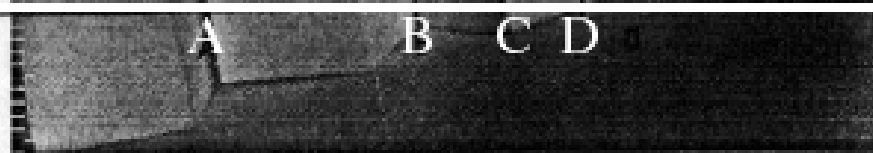
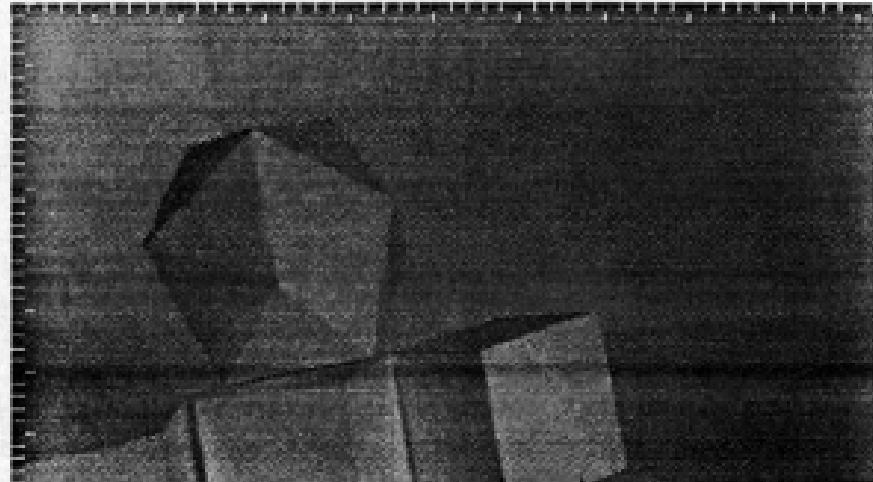

Interreflections

- Issue:
 - local shading model is a poor description of physical processes that give rise to images
 - because surfaces reflect light onto one another
 - This is a major nuisance; the distribution of light (in principle) depends on the configuration of every radiator; big distant ones are as important as small nearby ones (solid angle)
 - The effects are easy to model
 - It appears to be hard to extract information from these models

Interreflections

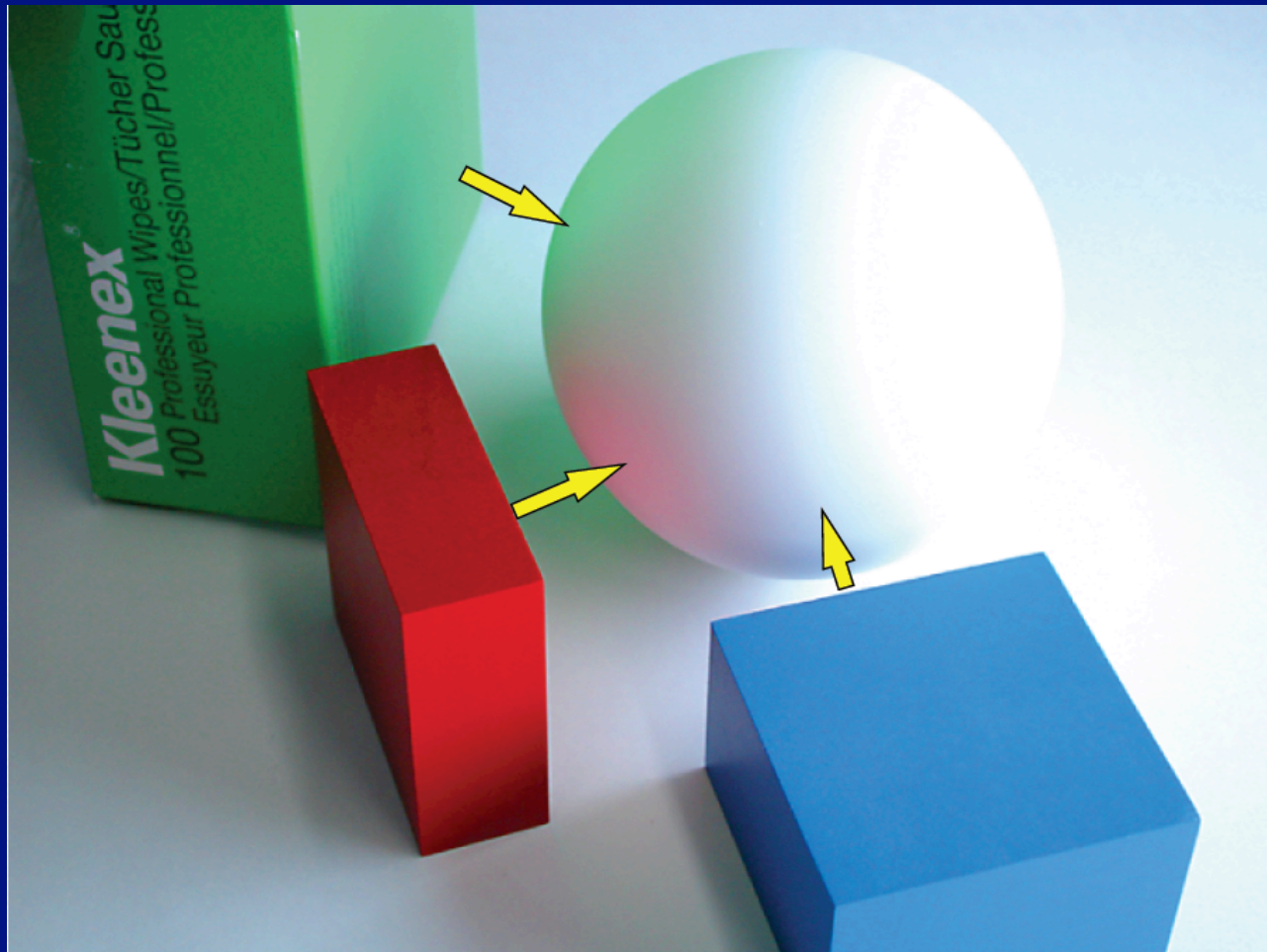

From Koenderink slides on image texture and the flow of light

Area sources

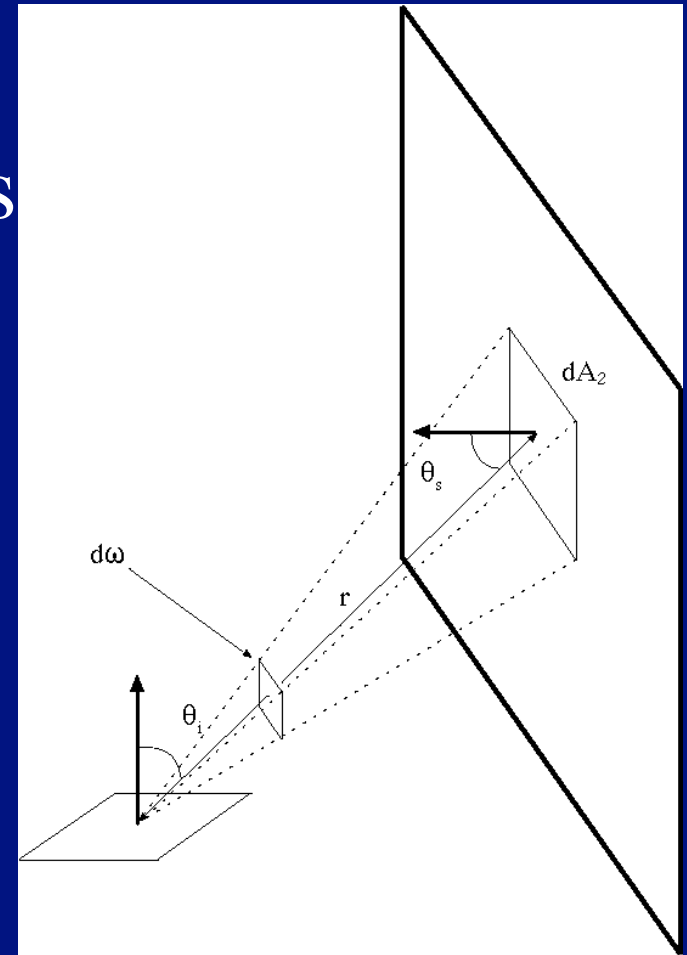

- Examples: diffuser boxes, white walls.
- The energy received at a point due to an area source is obtained by adding up the contribution of small elements over the whole source

Area Source Shadows

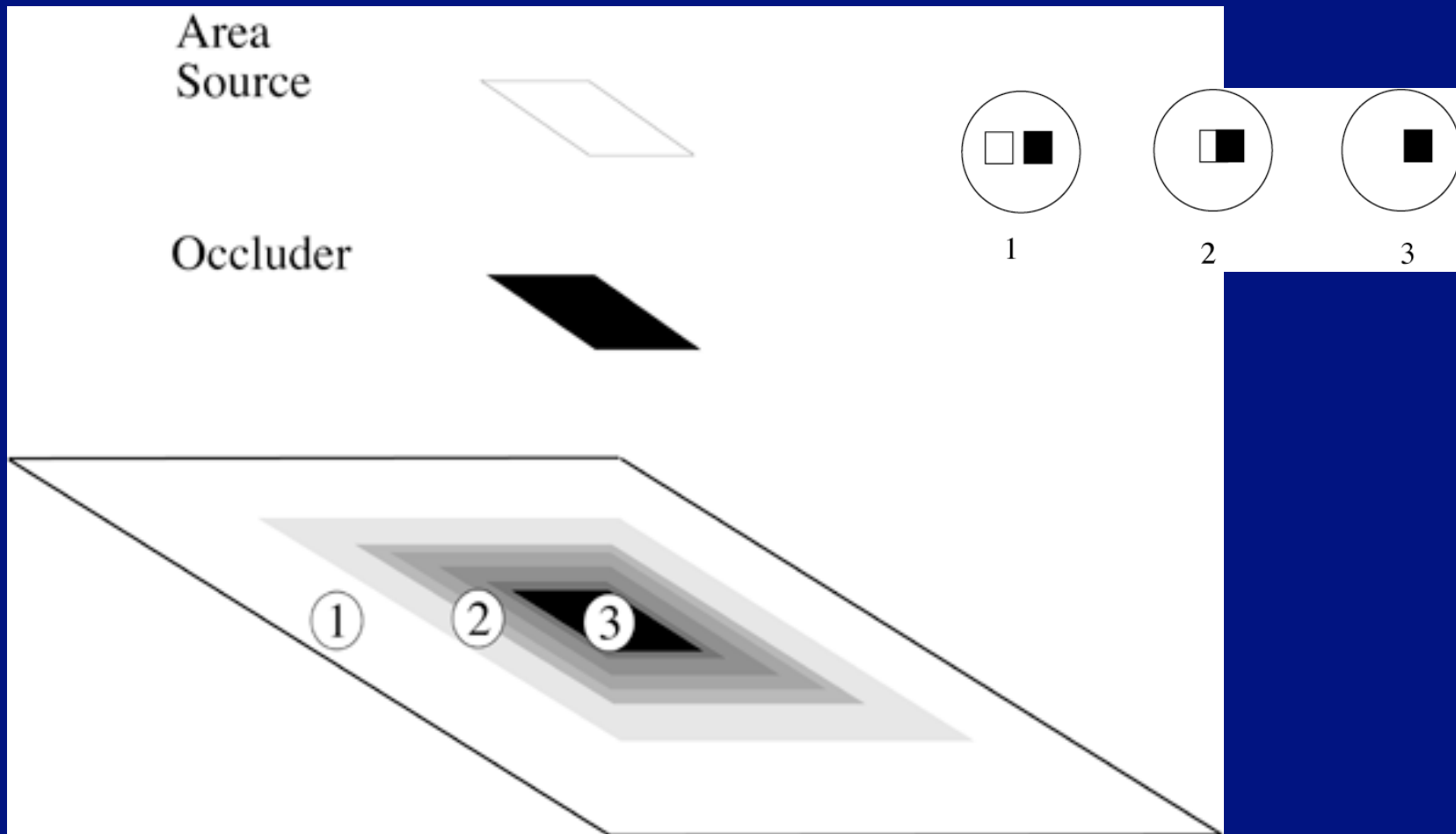

Shape from shading

- Recover a shape representation from the shading field
 - people seem to be able to do it
 - Qn's:
 - what shape representation?
 - how?
 - there is a story in computer vision, but we know it's wrong



Original with Tracking



Retextured Video



By Technicolour Yawp, on Flickr



From Koenderink slides on image texture and the flow of light

Causes of colour

- The sensation of colour is caused by the brain.
- One way to get it is the response of the eye to the presence/absence of light at various wavelengths.
 - Dreaming, hallucination, etc.
 - Pressure on the eyelids
- Light could be
 - emitted with wavelengths absent (fluorescent light vs. incandescent light)
 - differentially reflected - e.g. paint on a surface
 - differentially refracted - e.g. Newton's prism
 - subject to wavelength dependent specular reflection (most metals).
 - Fluorescence -
 - invisible wavelengths absorbed and reemitted at visible wavelengths.
 - Phosphorescence (ditto, energy, longer timescale)

XXXXX

BLUE

YELLOW

XXXXX

GREEN

BLUE

XXXXX

RED

GREEN

XXXXX

YELLOW

RED

XXXXX

BLUE

YELLOW

XXXXX

RED

GREEN

XXXXX

GREEN

BLUE

XXXXX

BLUE

YELLOW

XXXXX

YELLOW

RED

XXXXX

RED

GREEN

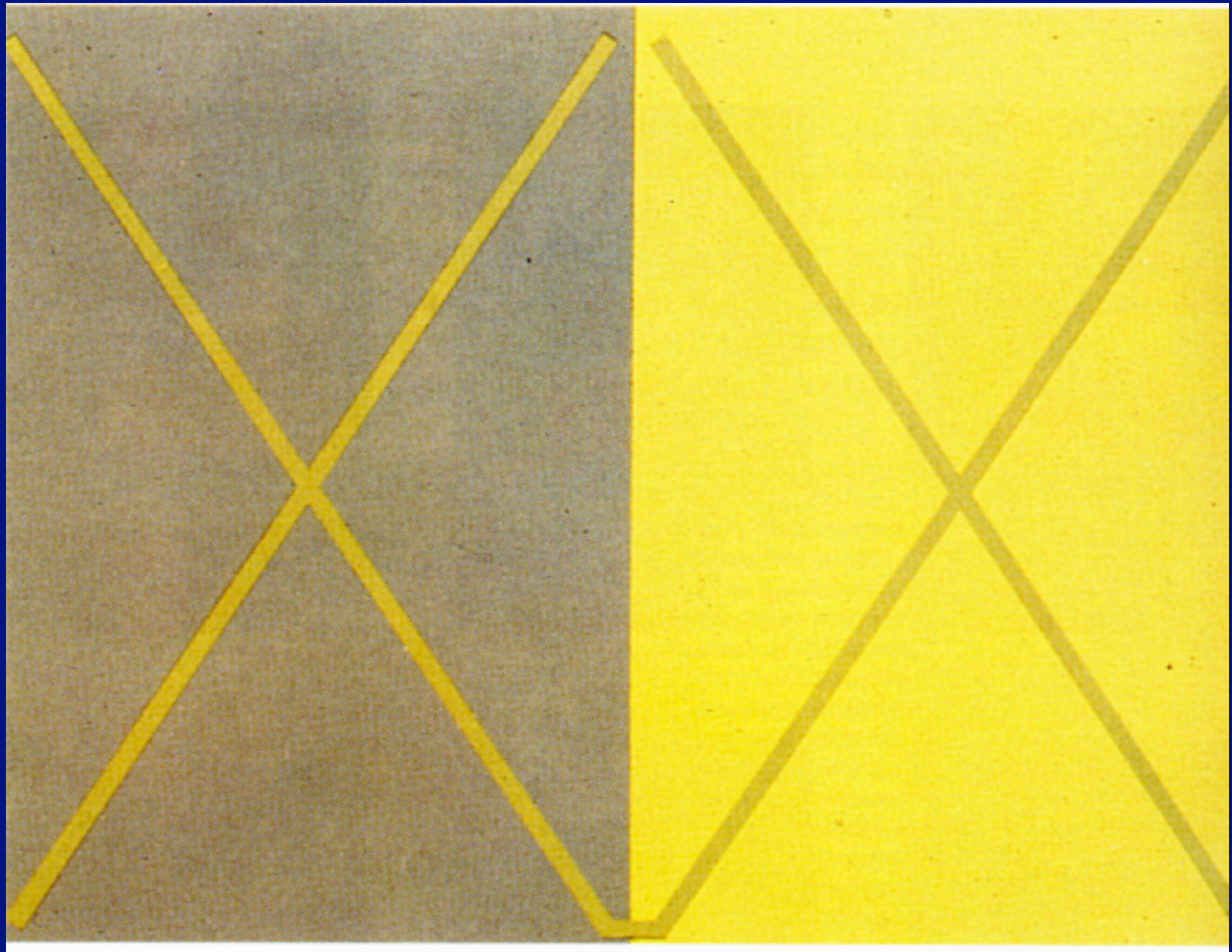

The color of objects

- Colored light arriving at the camera involves two effects
 - The color of the light source
 - The color of the surface
 - Changes caused by different colored light sources can be large

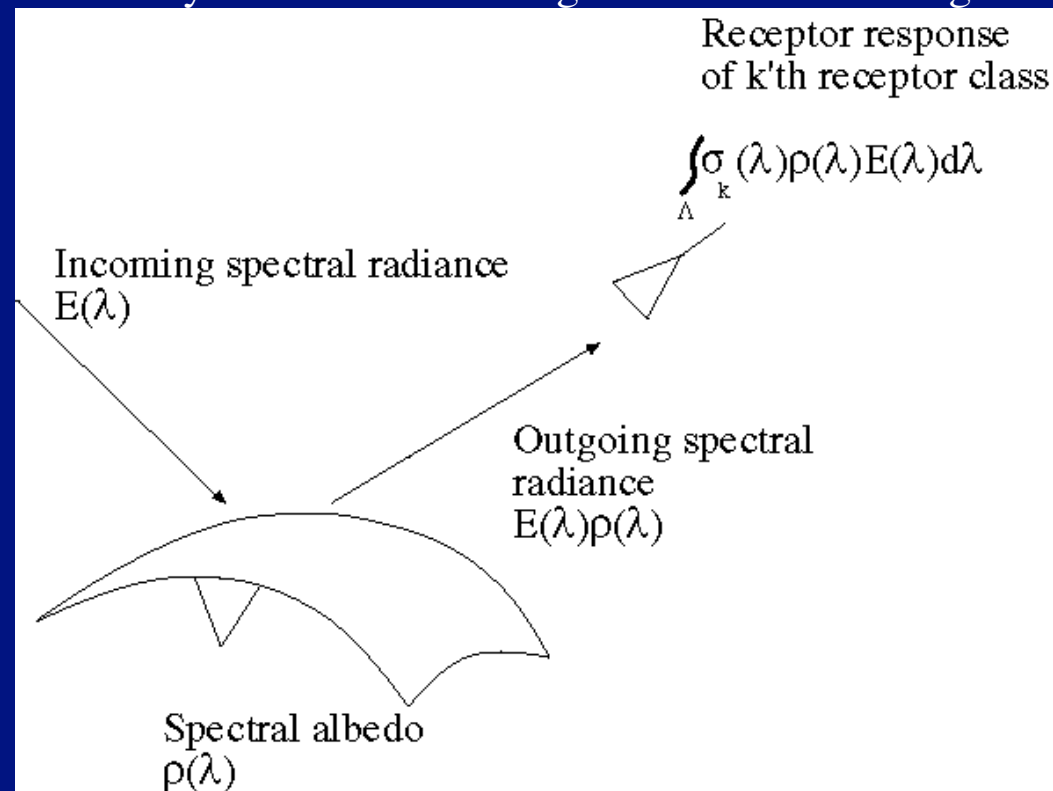

Color receptors and color deficiency

- Trichromacy is justified -
 - in color normal people, there are three types of color receptor (shown by molecular biologists).
- Some people have fewer;
 - most common deficiency is red-green color blindness in men. Red and green receptor genes are carried on the X chromosome. Most red-green color blind men have two red genes or two green genes. Yields an evolutionary story.
- Deficiency
 - can be caused by CNS, by optical problems in the eye, or by absent receptors
- Other color deficiencies:
 - Anomalous trichromacy
 - Achromatopsia
 - Macular degeneration

Color receptors

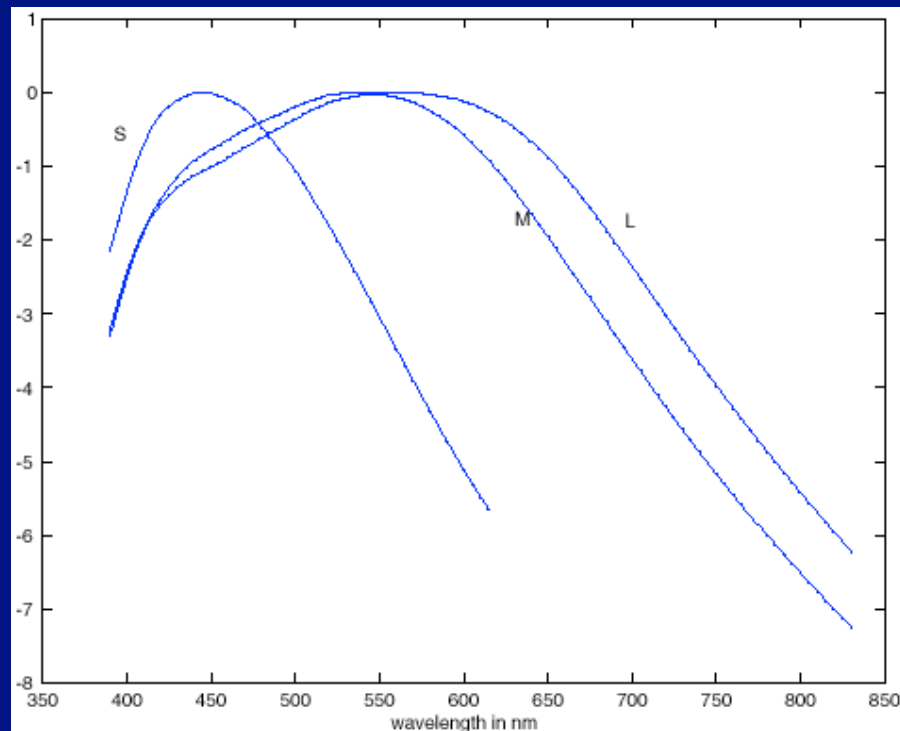

Principle of univariance: cones give the same kind of response, in different amounts, to different wavelengths. Output of cone is obtained by summing over wavelengths.

Responses measured in a variety of ways

Leaf reflectances

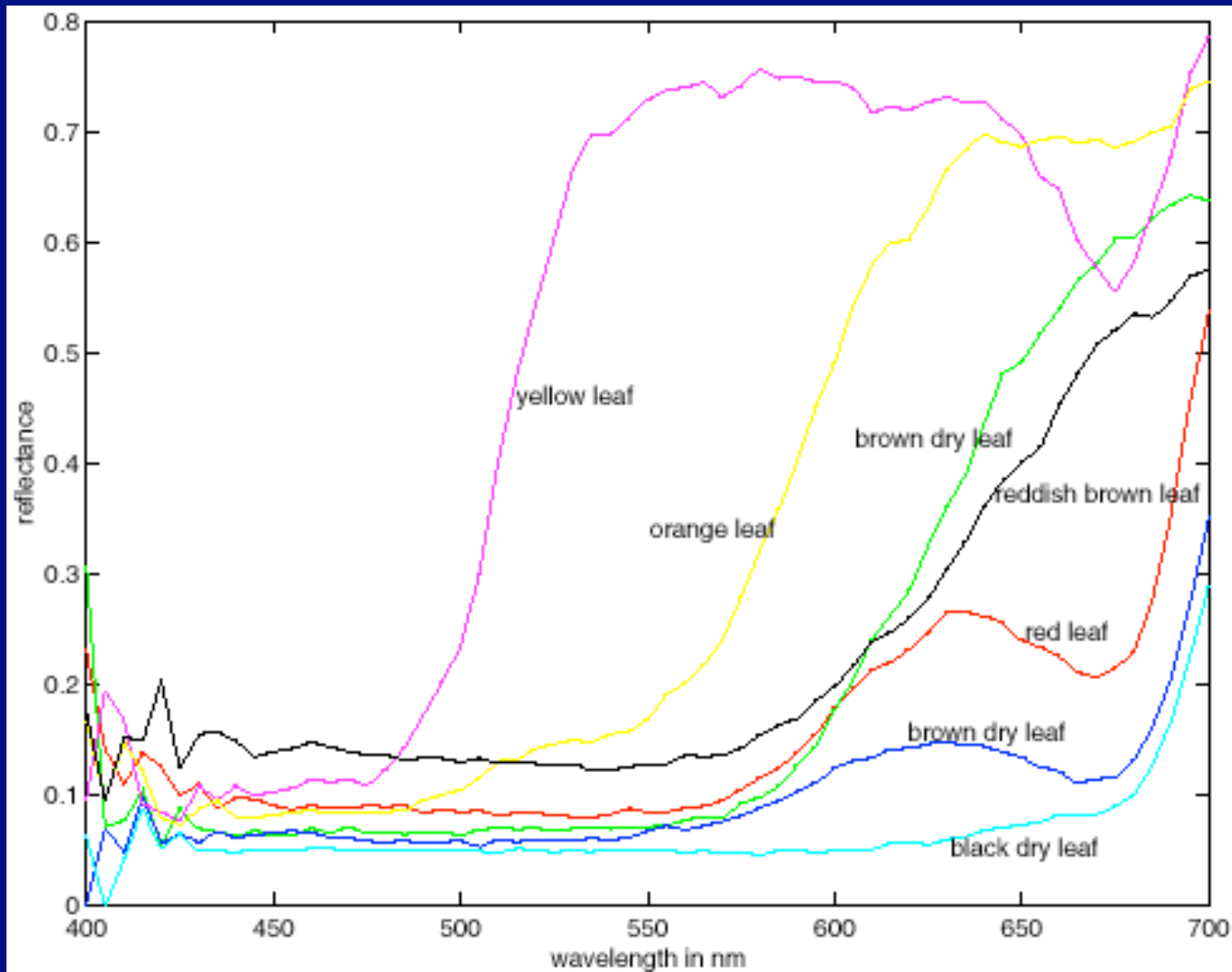

Petal reflectances

Different
red flowers

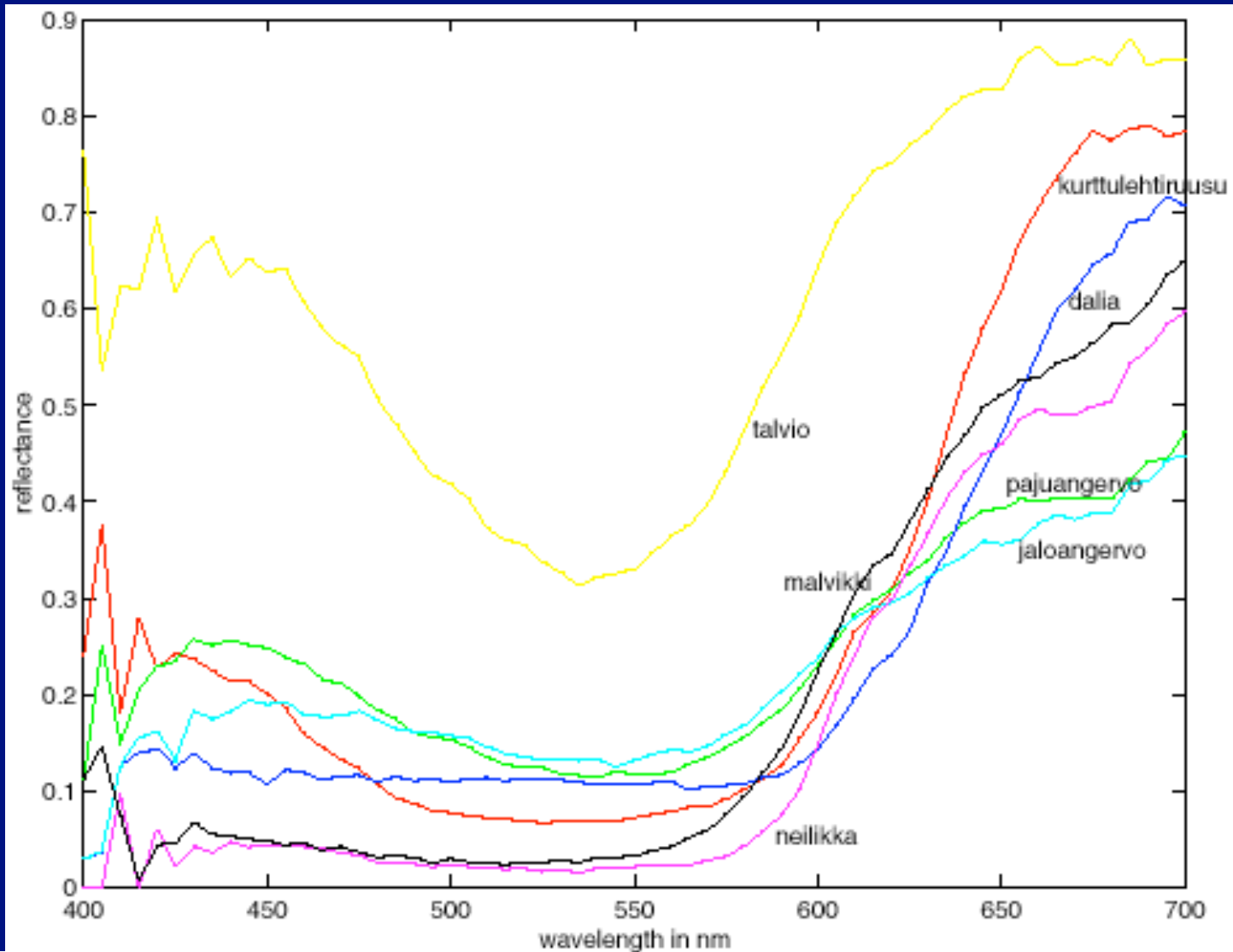

Petal reflectances

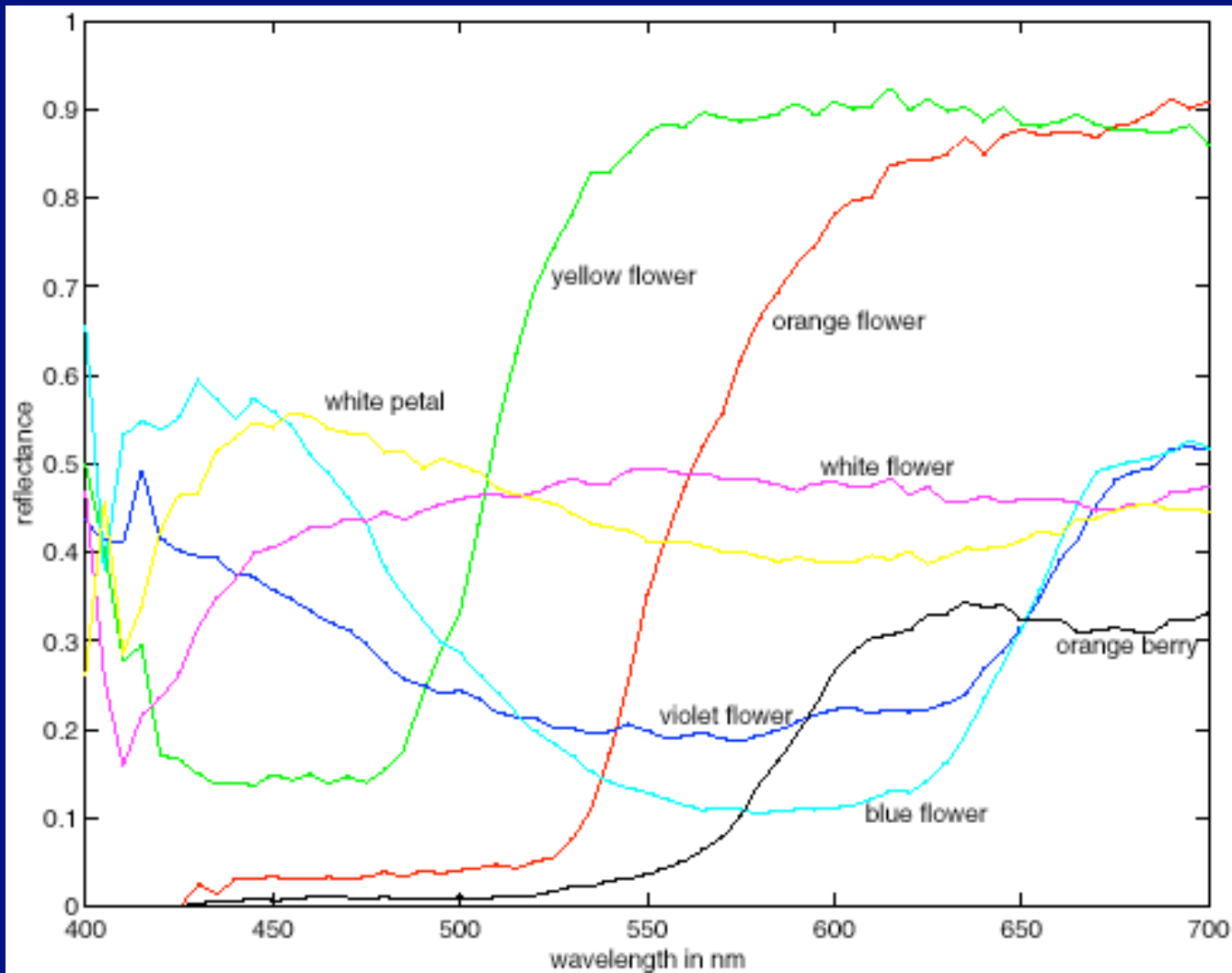

Different lights on uniform reflectances

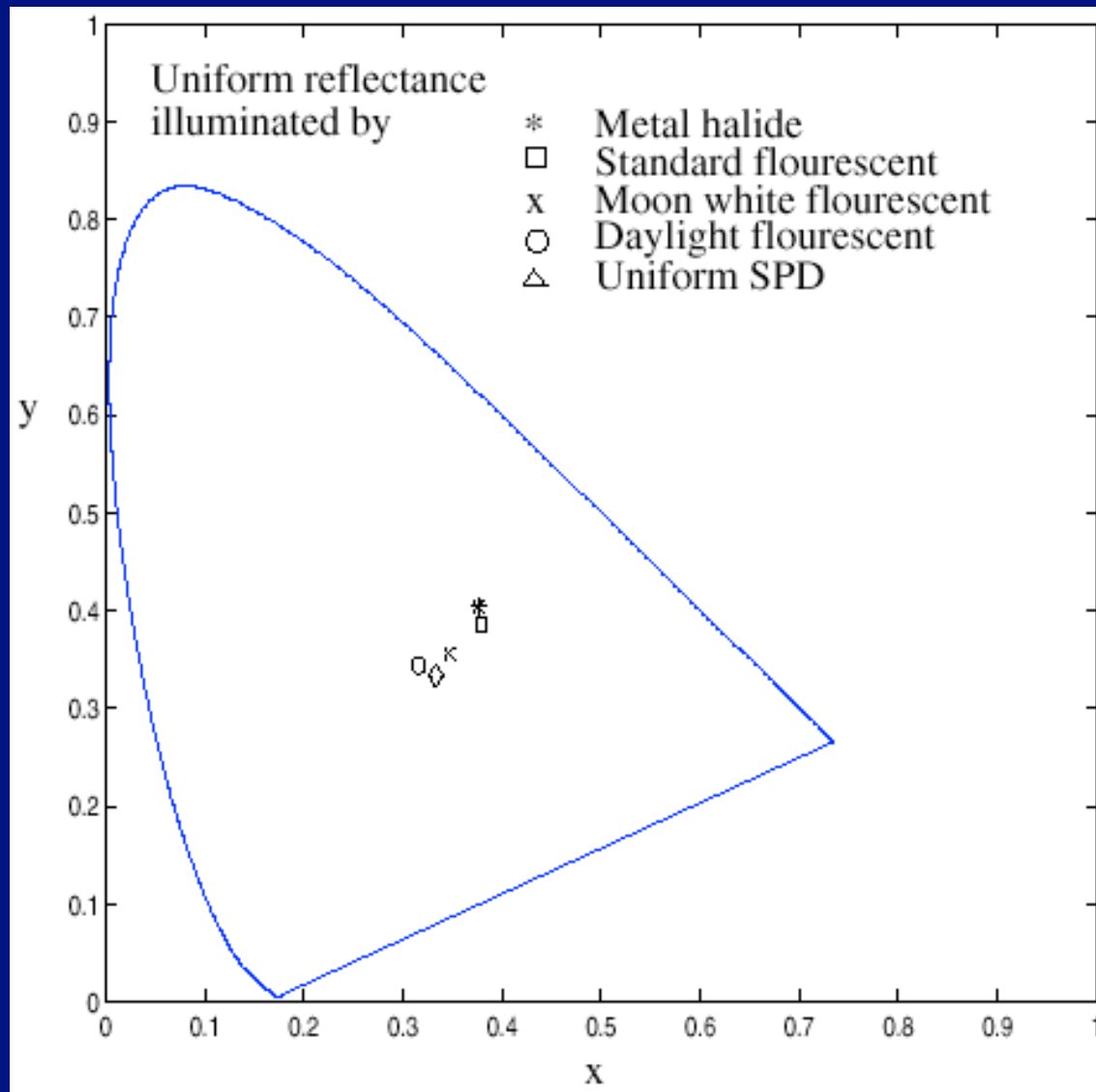
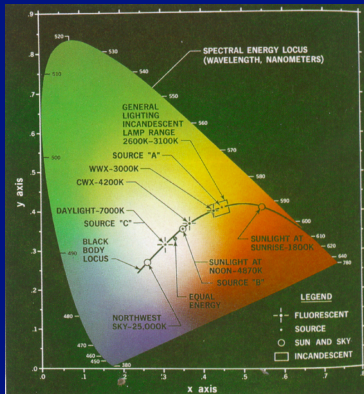

Different lights on blue flower

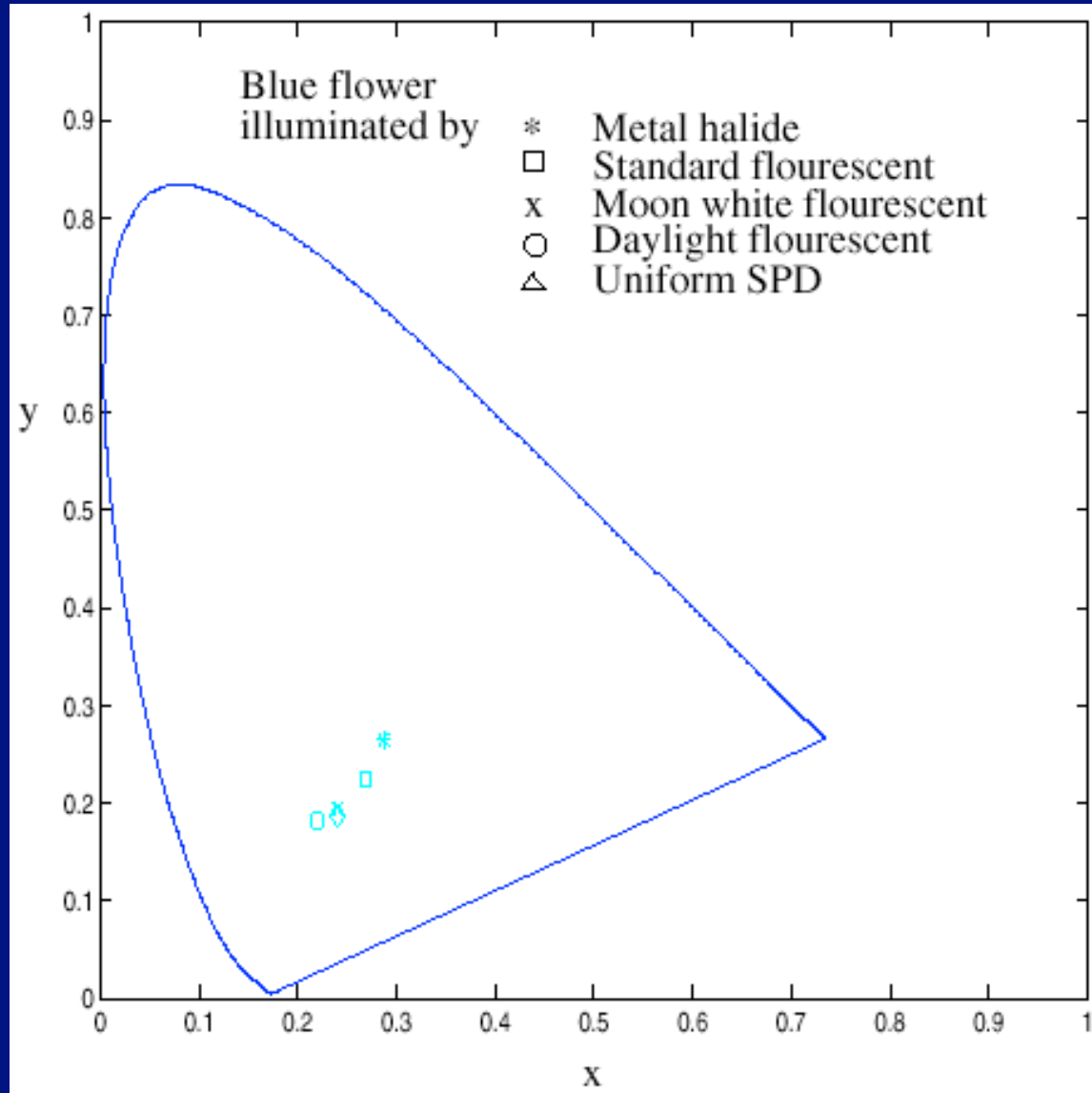
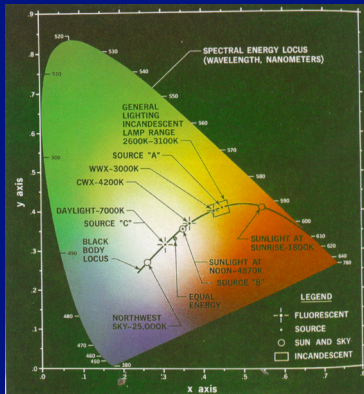

Different lights on green leaf

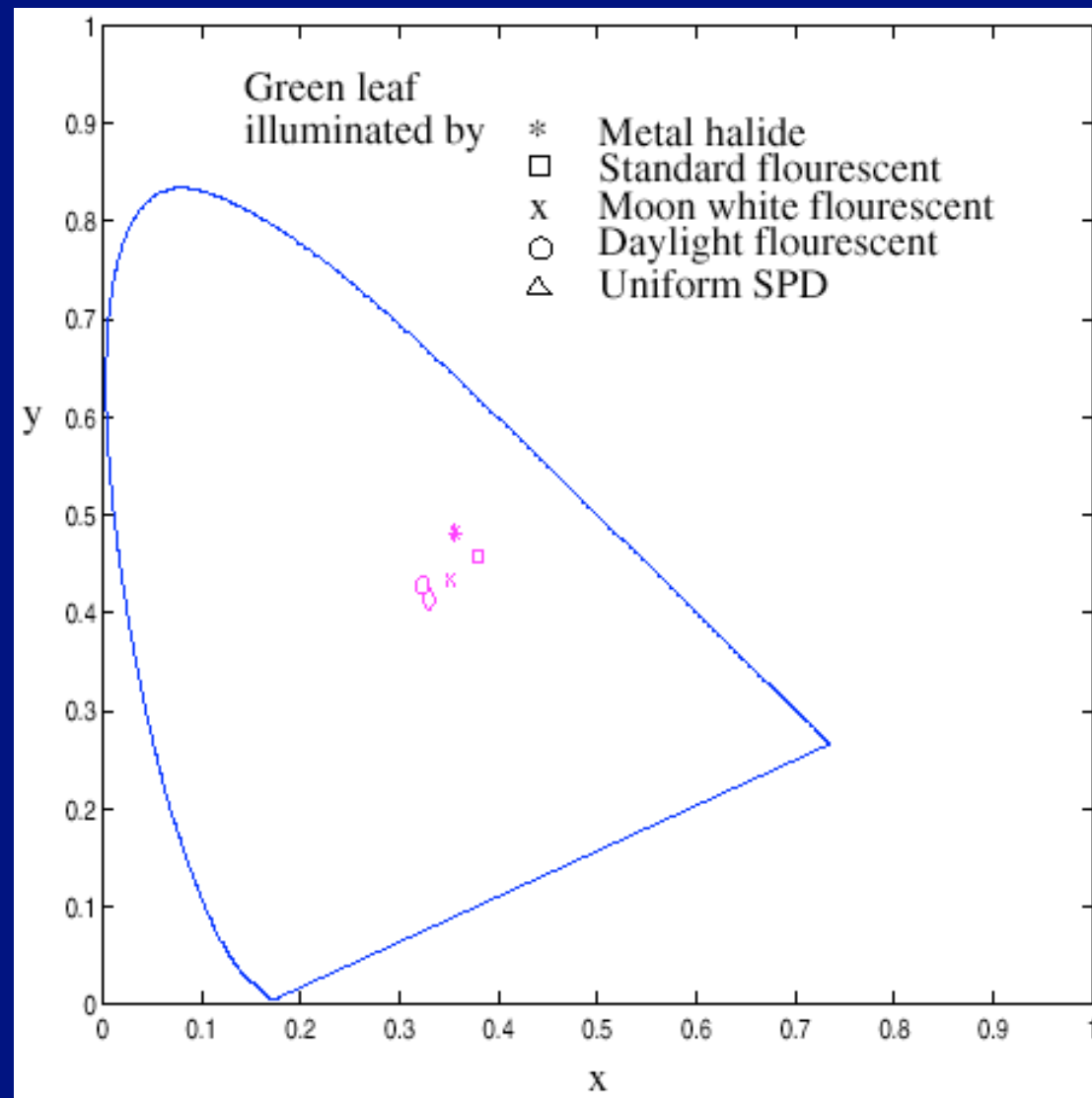
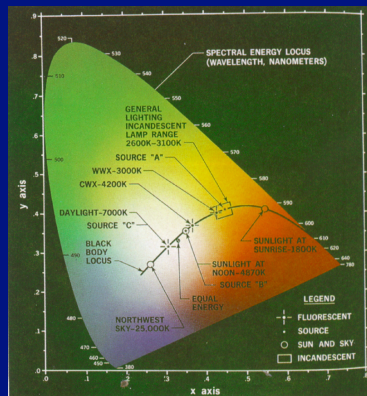

Land's Demonstration

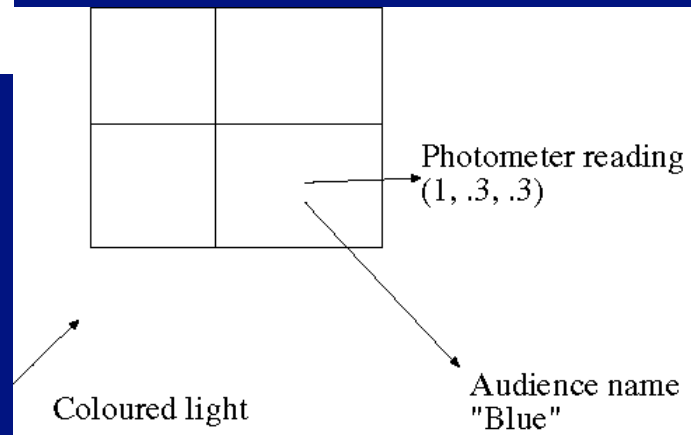
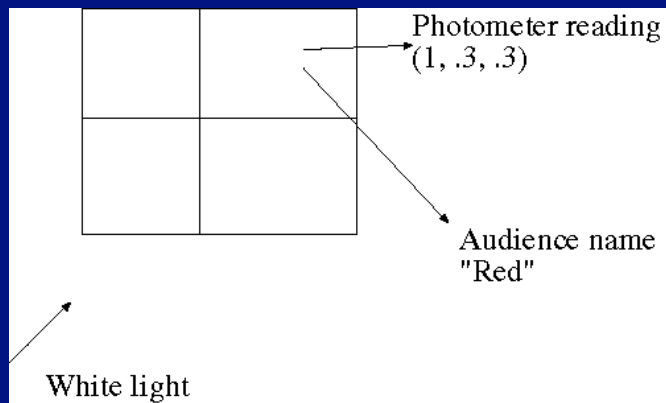



By nickwheeleroz, on Flickr

Lightness Constancy

- Lightness constancy
 - how light is the surface, independent of the brightness of the illuminant
 - issues
 - spatial variation in illumination
 - absolute standard
 - Human lightness constancy is very good
- Assume
 - frontal 1D “Surface”
 - slowly varying illumination
 - quickly varying surface reflectance

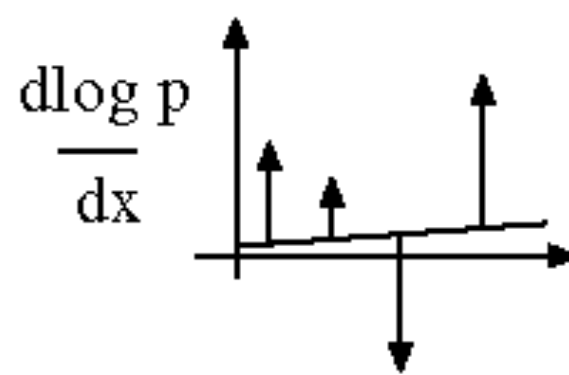
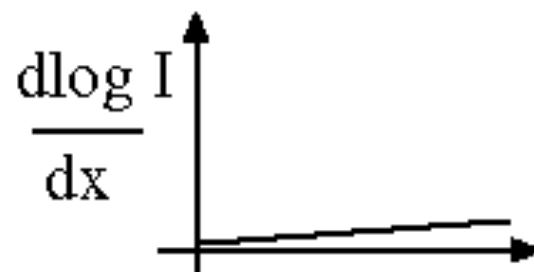
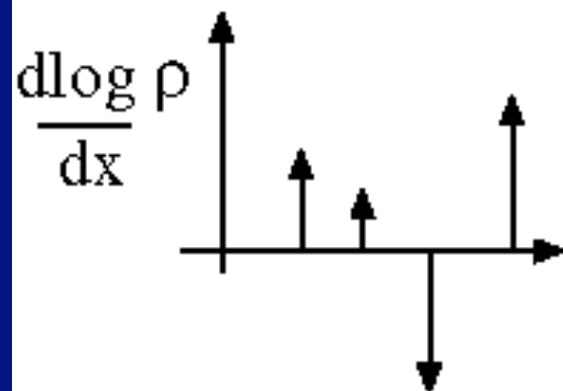
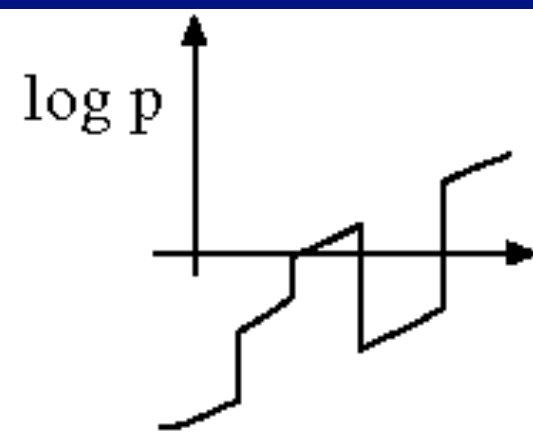
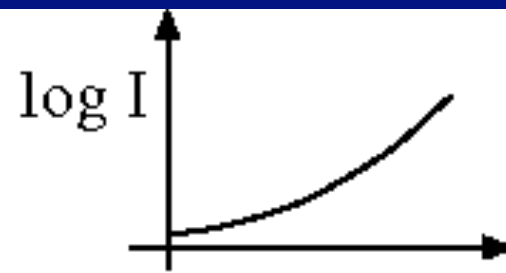
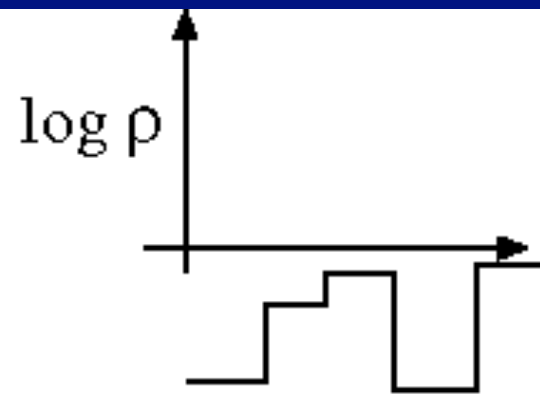

Thresholded

$$\frac{d \log p}{dx}$$

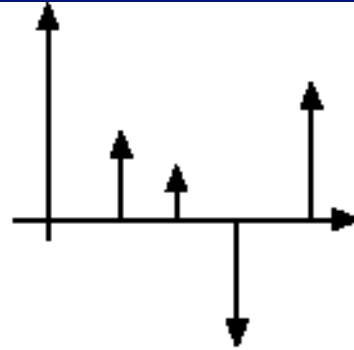

Integrate
This to get

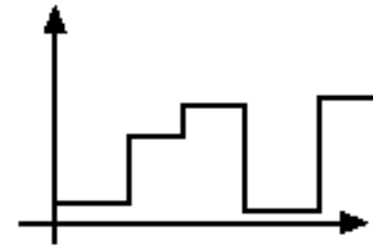



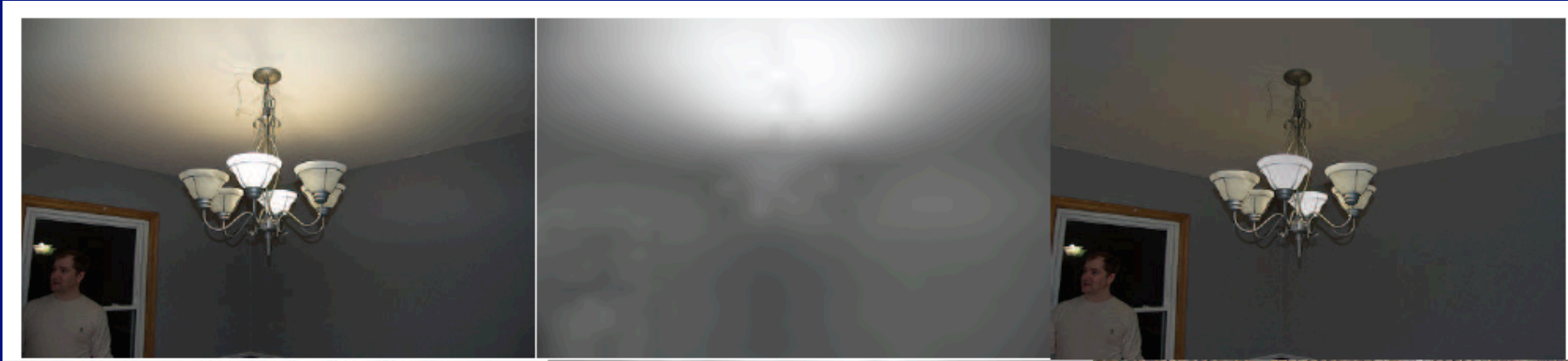

Karsch et al in review 10

Simplest colour constancy

- Adjust three receptor channels independently
 - Von Kries
 - Where does the constant come from?
 - White patch
 - Averages
 - Some other known reference (faces, nose)

Stage lighting



From Koenderink slides on image
texture and the flow of light





Karsch et al in review 10